

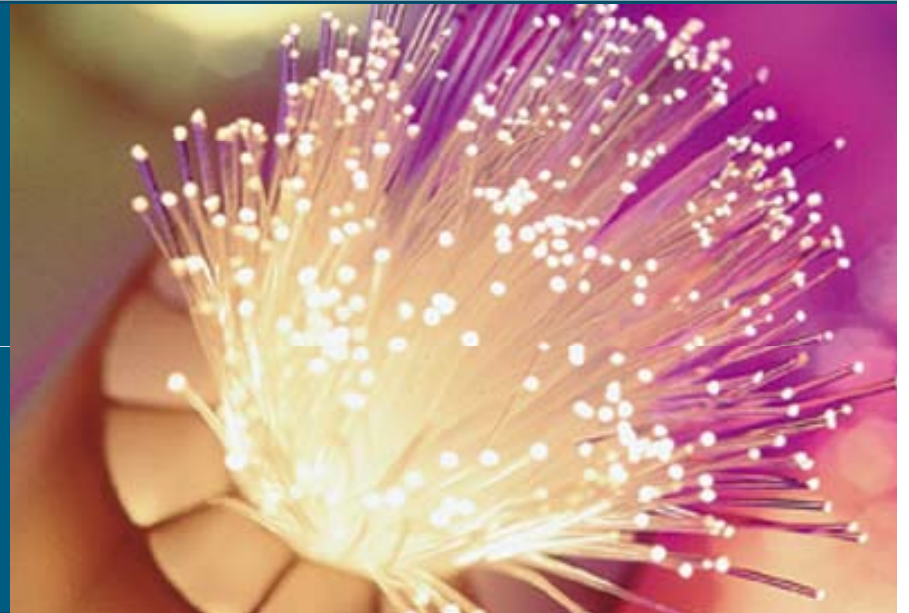

# 100Gb/s: A Case for Standards



**Bill Gartner**

**VP/GM Optical Transport Business Unit**

# Topics

- Background
- Advantages of Standardization
- Concerns over Standardization
- 100Gb/s DWDM

# Background

- ITU, IEEE, OIF all making good progress on 100G standards
- Client-side (SR) optics will be defined
  - Ethernet (IEEE 802.3ba)
  - OTU4 (ITU SG-15)
- Line side (DWDM) optics:
  - Work started in OIF
  - Projects include FEC, MSA, Transceiver
  - Debate about how much should be standardized, and when

# Background – Line Side

- Optical transport industry was proprietary (circa 1980s), then standardized around SONET & SDH in ANSI & ITU
- DWDM technology introduction resulted in shift towards proprietary solutions:
  - Improving Bandwidth x Distance Figure of Merit
- 40G flavors:
  - ODB, CSRZ, DPSK, DQPSK, PM-QPSK, OFDM...
- Proprietary solutions result in industry fragmentation. Realities of this fragmentation are:
  - Component supply base has limited addressable market
  - Test equipment vendors unable to fully support market
  - Market incumbency is protected, but market size is constricted
  - Encourages incremental innovation

# Advantages of Standardization

- **Supply base:**

- Common interface specifications drive commonality of components and modules which provides:
  - Larger addressable market for component vendors
  - Larger supply base for system integrators
  - Economies of scale resulting in lower cost across the industry at all levels

- **Vendor adoption:**

- Faster adoption of new technology since multiple suppliers of same technology reduce sole-source risks
- Less development and deployment risk
- Faster market growth, e.g., Ethernet
- Test equipment availability

# Concerns over Standardization

- **Arguments against standardization:**
  - Stifles innovation and technology investment
  - Restricts product differentiation
  - Standardization in the extreme leads to commoditization
- **Innovation:**
  - Need to separate paradigm innovation from incremental innovation
  - Standardization does not prevent paradigm innovation
    - Many examples (SONET, Wireless, 10BaseT in Ethernet, ...)
  - Standardization does (hopefully) hinder incremental innovation
- **But, Timing Matters...**

# Timing matters...

- **Standardize too early...**

- Risk of standardizing on an emerging but inferior option
- May result in “least common denominator”

- **Standardize too late (or never)...**

- Industry never obtains overall benefits:
  - Fragmentation results
  - Inefficient use of industry resources
  - Scale benefits (cost) not realized

- **When to standardize?**

- Depends on maturity and complexity of technology
- Commercial success not necessarily tied to “optimal” solution

# Innovation Life Cycle

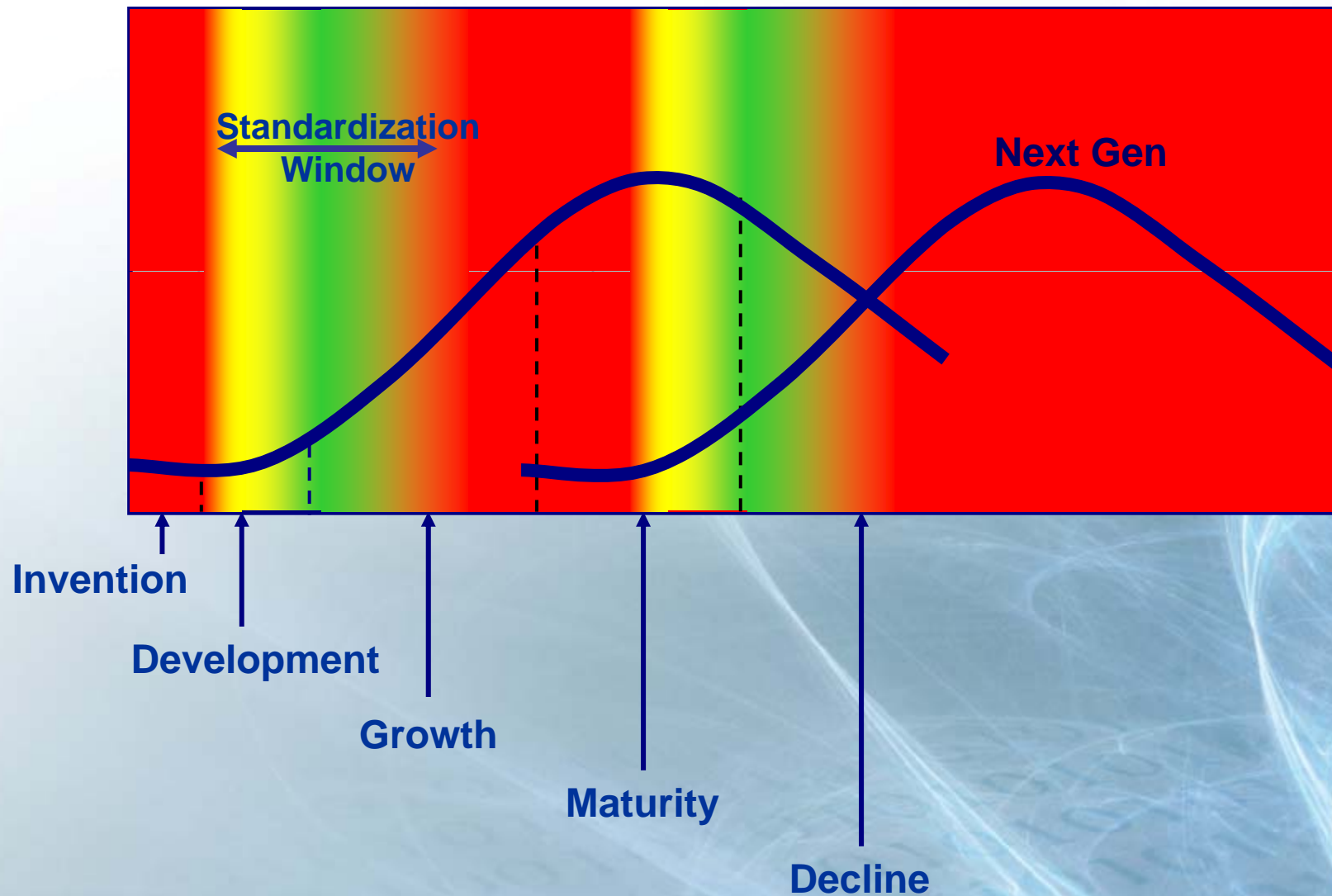

# Sources of differentiation

- Solution level differentiation:
  - Multiple product domains (e.g. Network management, IP/Ethernet/Optical)
- System level differentiation (examples):
  - System architectures that provide significant cost advantage
  - BW x Distance Figure of Merit:
    - EDFAs/Raman
    - Tx/Rx performance gain
    - Wavelength count
    - Bit rate increase
  - Capacity management:
    - ROADM
    - Intelligent transponders (MSPP on a blade, L2 crossponders, etc.)
    - Omni-directional optical switching
  - Network Management/NE software/planning tools:
    - Intelligent networking/planning
    - Alarm/fault correlation
    - Rapid protection switching/restoration

# 100GE - What is being Standardized ?

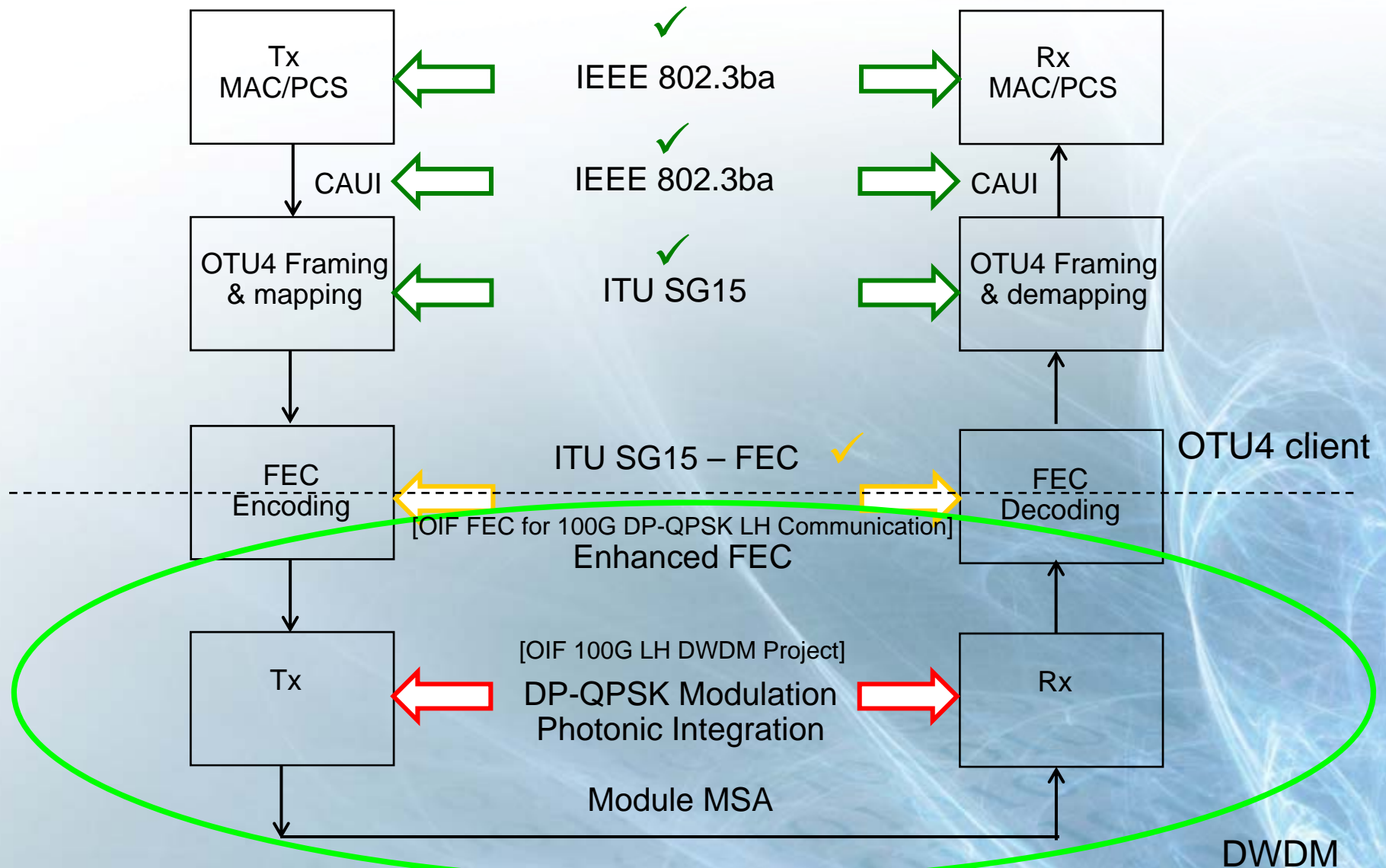

# Video Apps Approach the Zettabyte Era

## Increasingly Bandwidth Intensive and Complex



**44 Exabytes per month Total Traffic by 2012**  
 2012 annual bandwidth demand reaches 522 Exabytes, or more than half of a Zettabyte

**Residential HD Video**



**Bi-Directional Mobile Video**



**Massive Online Video Storage Libraries**



**Business HD and 3-D Video**



**Personalized Event Driven Content**



**Consumer Traffic Trend**

Video Reaches 87% of Consumer IP in 2012

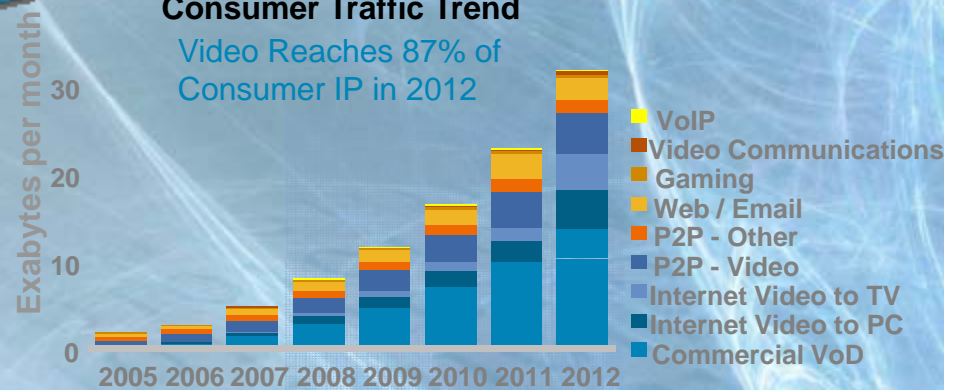

Source: Cisco, 2008

# Summary

- Benefits of Standardization:
  - Increased industry efficiency
  - Reduced costs (scale)
- Timing matters: preserve opportunities for innovation
- Good progress being made on 100G
- Industry should consider 100G DWDM line side standard
- Begin thinking about > 100G