

The image shows a close-up of a white industrial machine with the 'Infonera' logo in blue and yellow. The machine is part of a larger factory or manufacturing environment, with yellow overhead cranes and other equipment visible in the background. Two people are standing in the distance, looking at something. The lighting is bright and industrial.

Infonera

“Bits per Chip”

Dave Welch

Co-Founder and Chief Marketing and Strategy Officer

Optical Network Issues

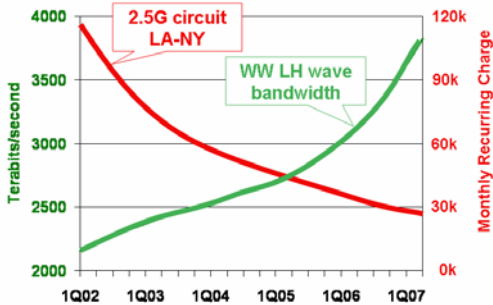

**Bandwidth
Demand**

How many GEs?
2.5G? 100GbE?
40G? L1VPN?
OTN? Ethernet?
Traffic matrix?

**Services
Uncertainty**

Operations

Competitive
Pressures &
Opportunities

**Speed, Service
Differentiation**

The “10x” Problem

- 10x Higher Speed Services – 100 GbE
- 10x Higher Capacity
- 10x Greater Density - ~ 1Tb/linecard
- 1/10 Cost/bit/network
- 1/10 Power consumption
- 10x Reliability

- Simultaneously...

Infinera Architecture

- New services are added digitally
 - Wavelengths are virtualized into digital bandwidth

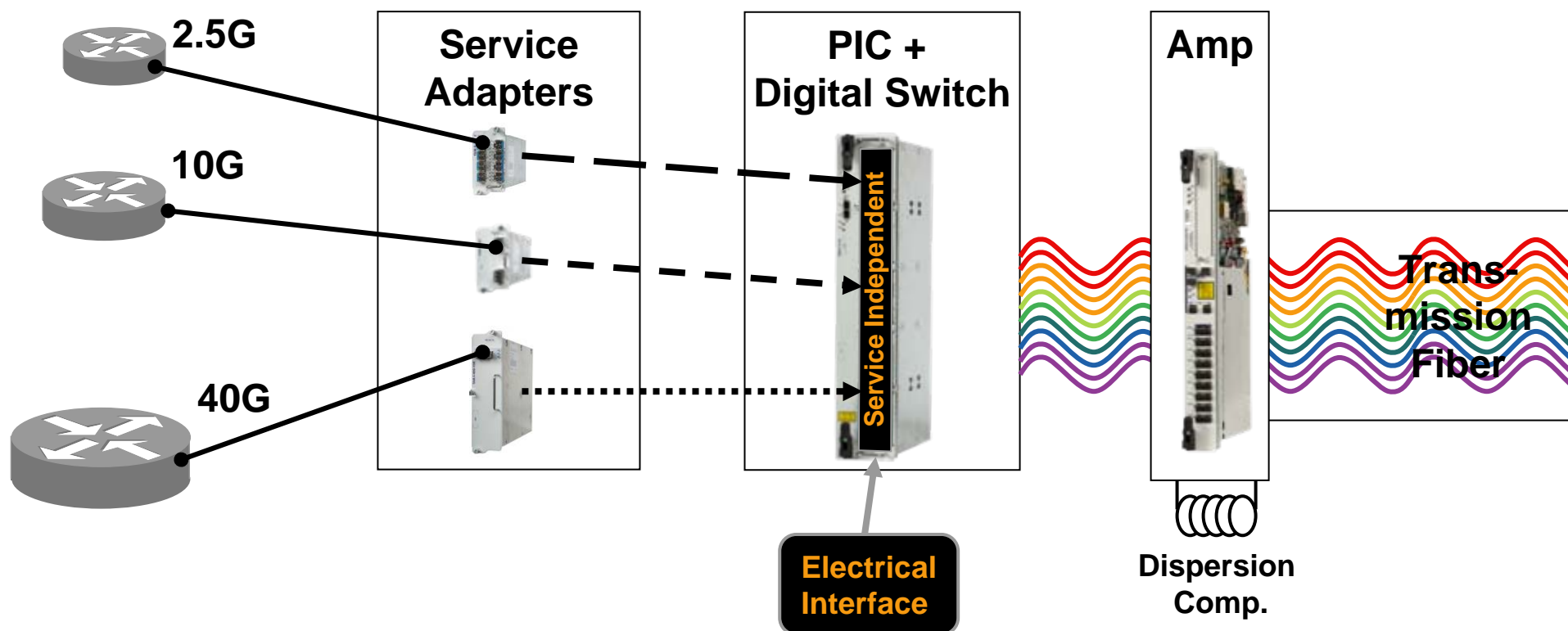

A Programmable Optical Network

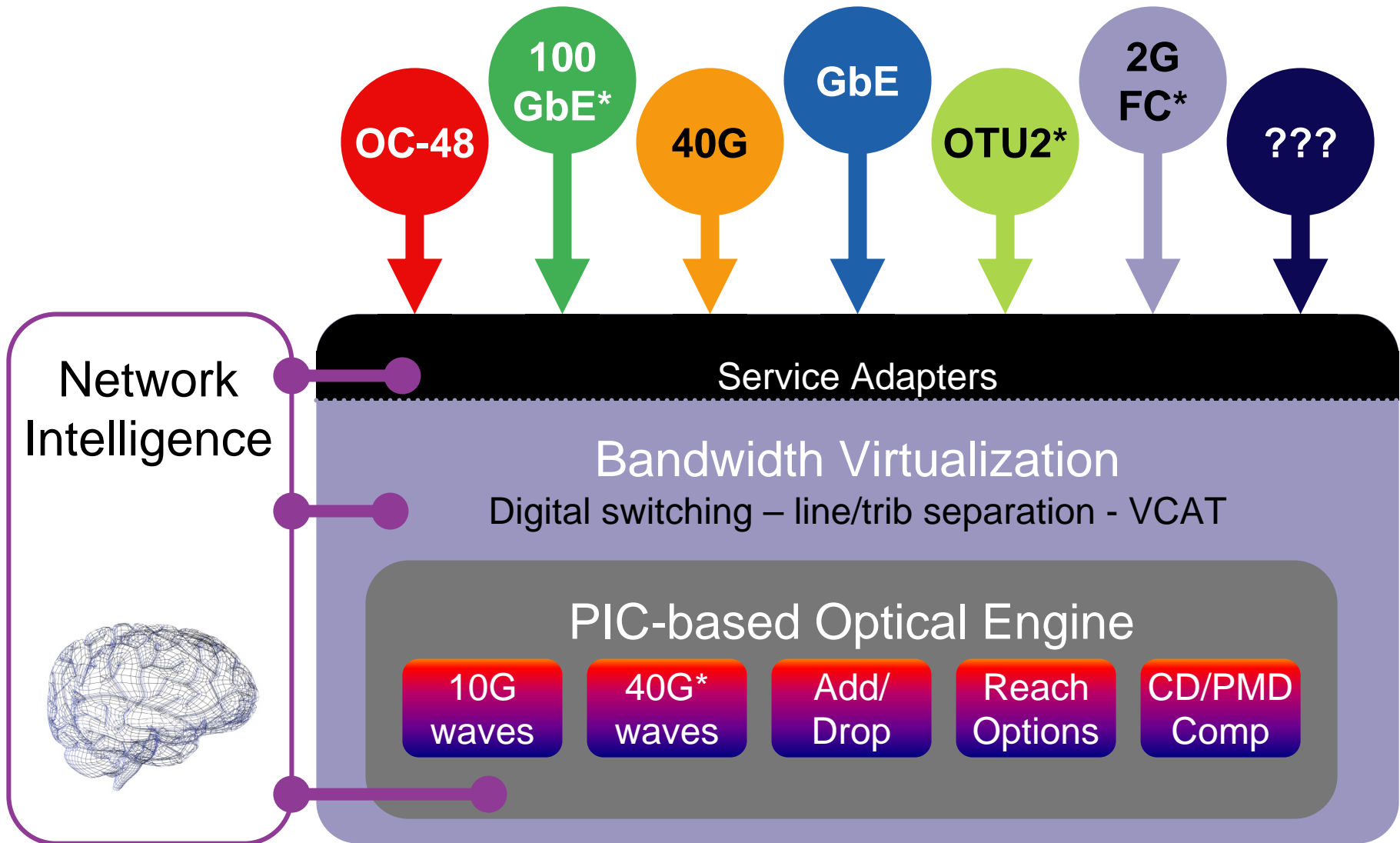

* Future product

Today's Focus: The Optical Engine

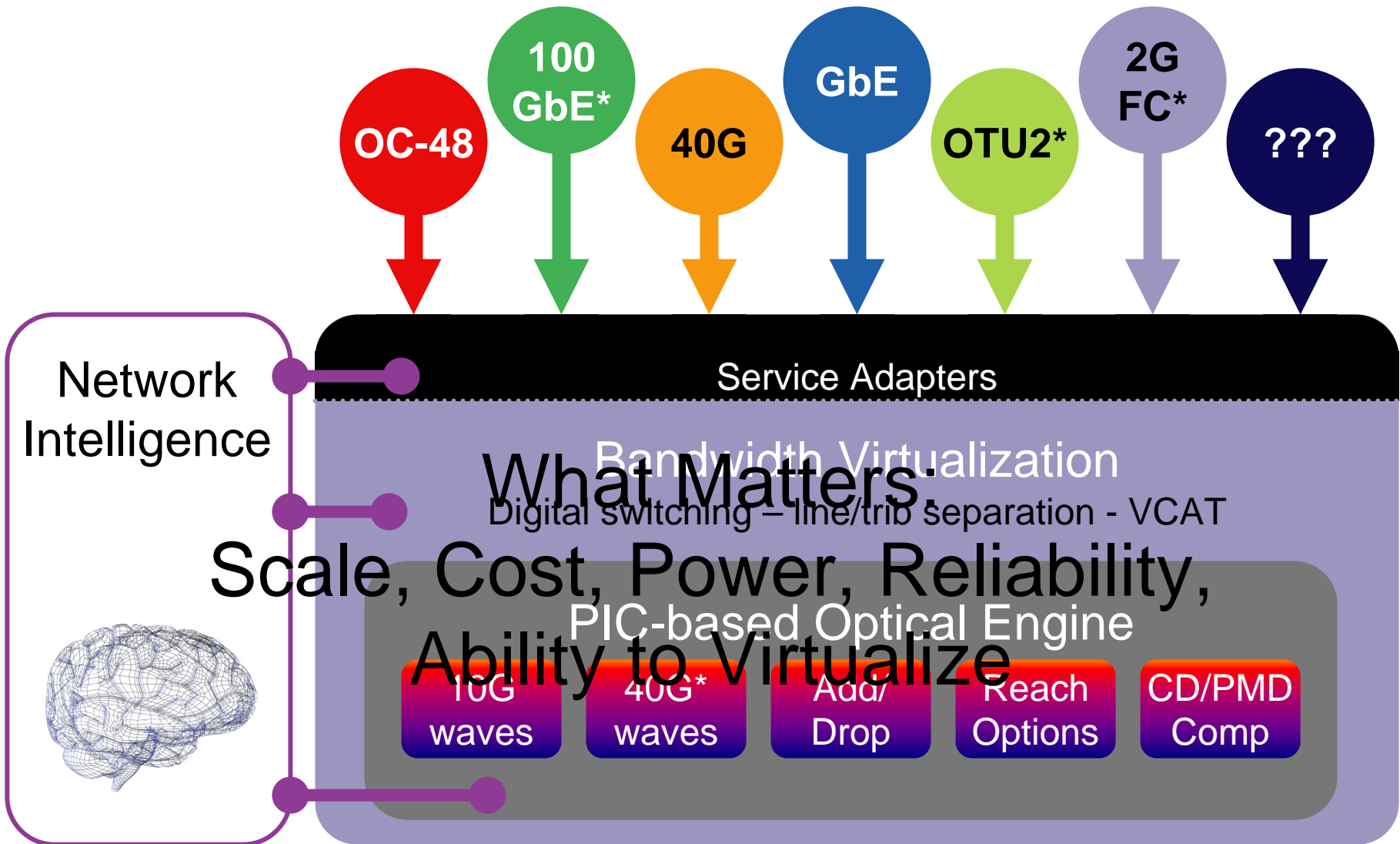

* Future product

PIC benefits...

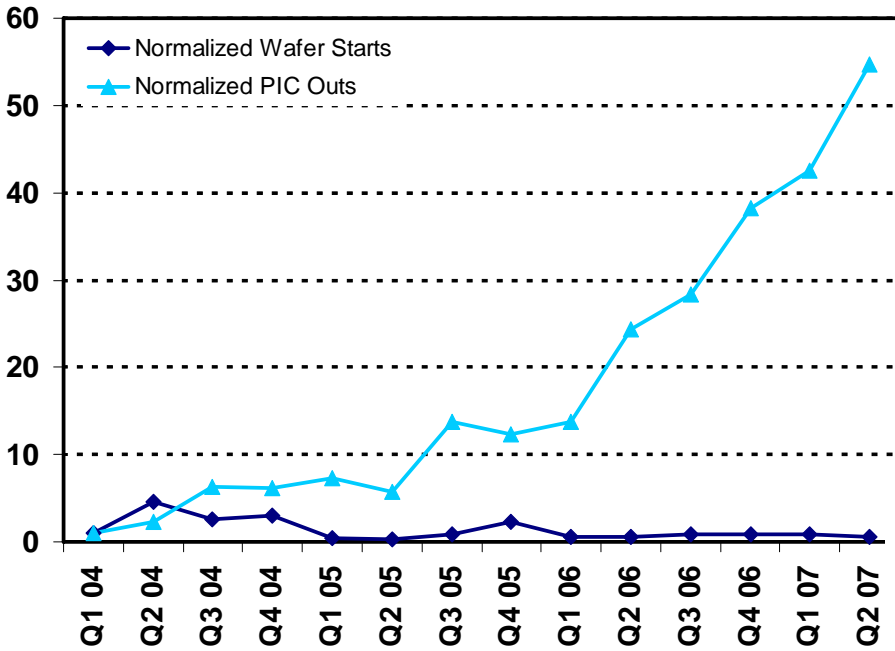

Radical improvement in reliability

60X increase in wafer utilization

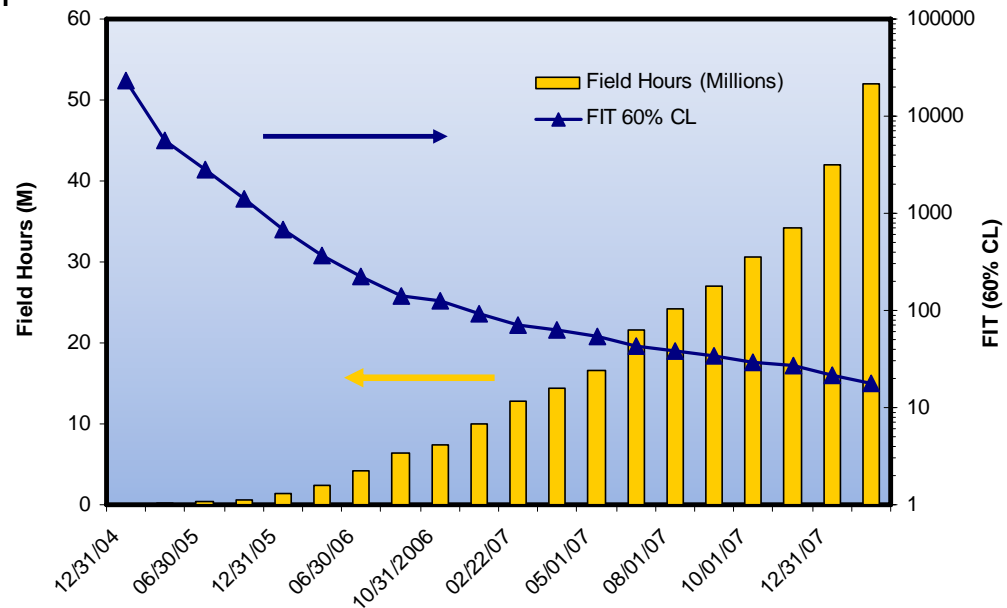

Functional Architecture: Simple vs. Complex Modulation

10G NRZ Transmitter

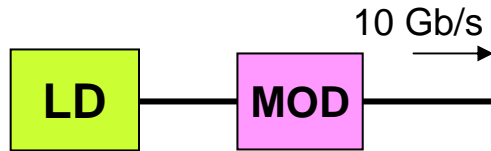

40G PM-DQPSK Transmitter

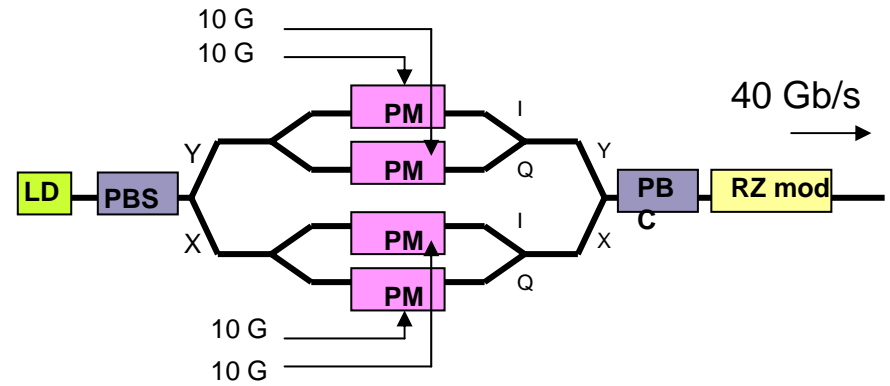

10G NRZ Receiver

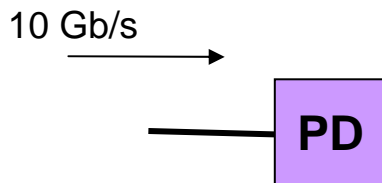

40G PM-DQPSK Receiver

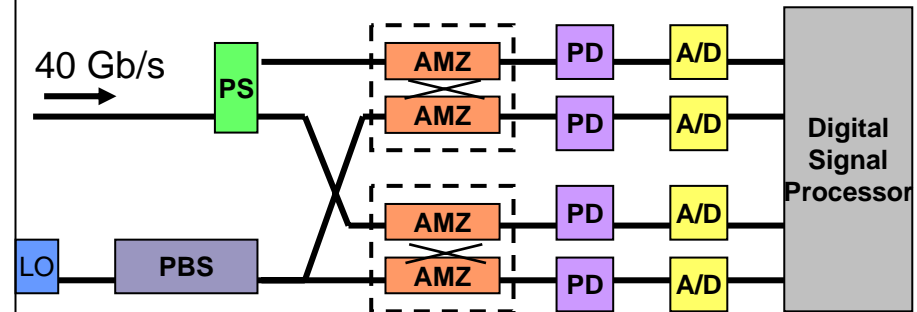

Large-Scale DWDM DQPSK Tx PIC

10 Channels x 40 Gb/s

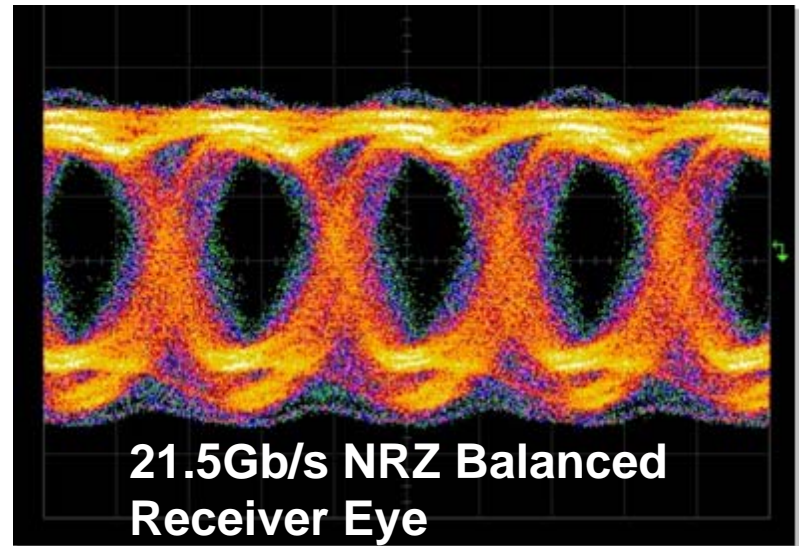
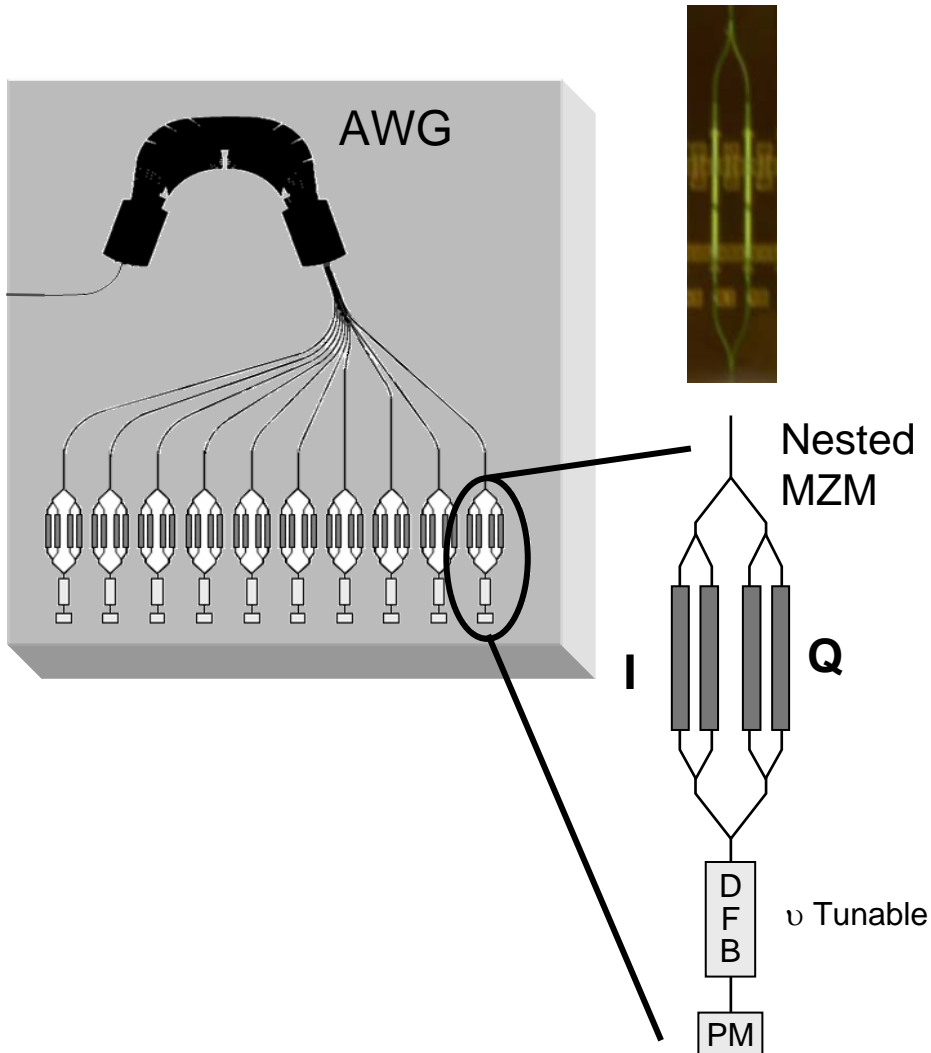

OFC/NFOEC Post-deadline:
10-Channel x 40Gb/s per channel
DQPSK Monolithically Integrated
InP-based Transmitter PIC

PIC Roadmap

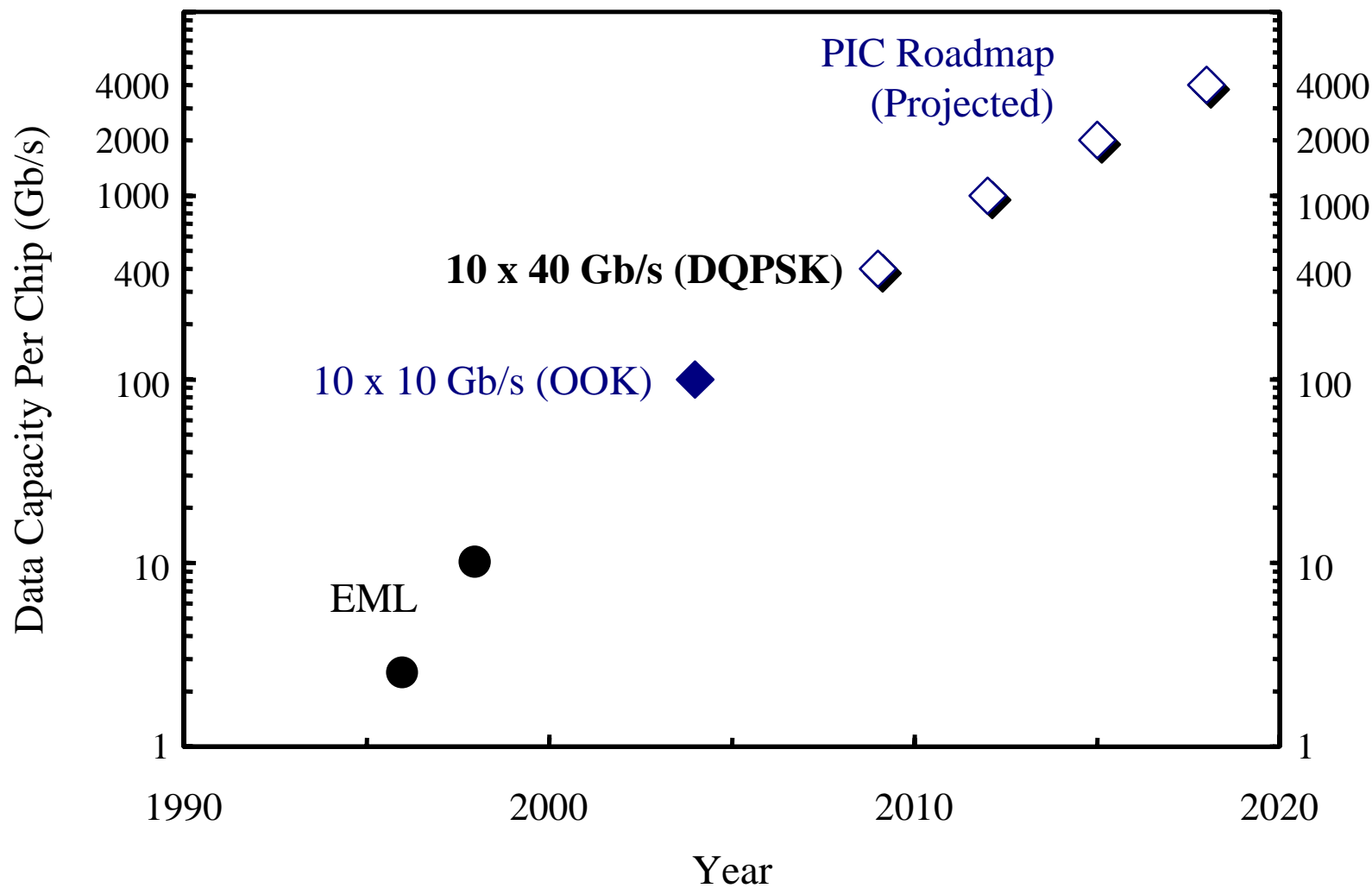

1490 nm S- band PIC transmission over 320 km

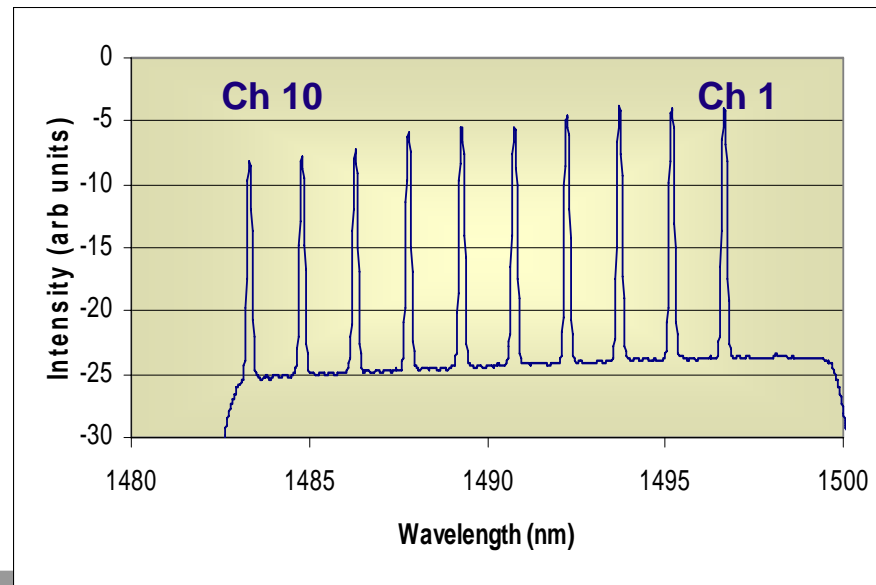
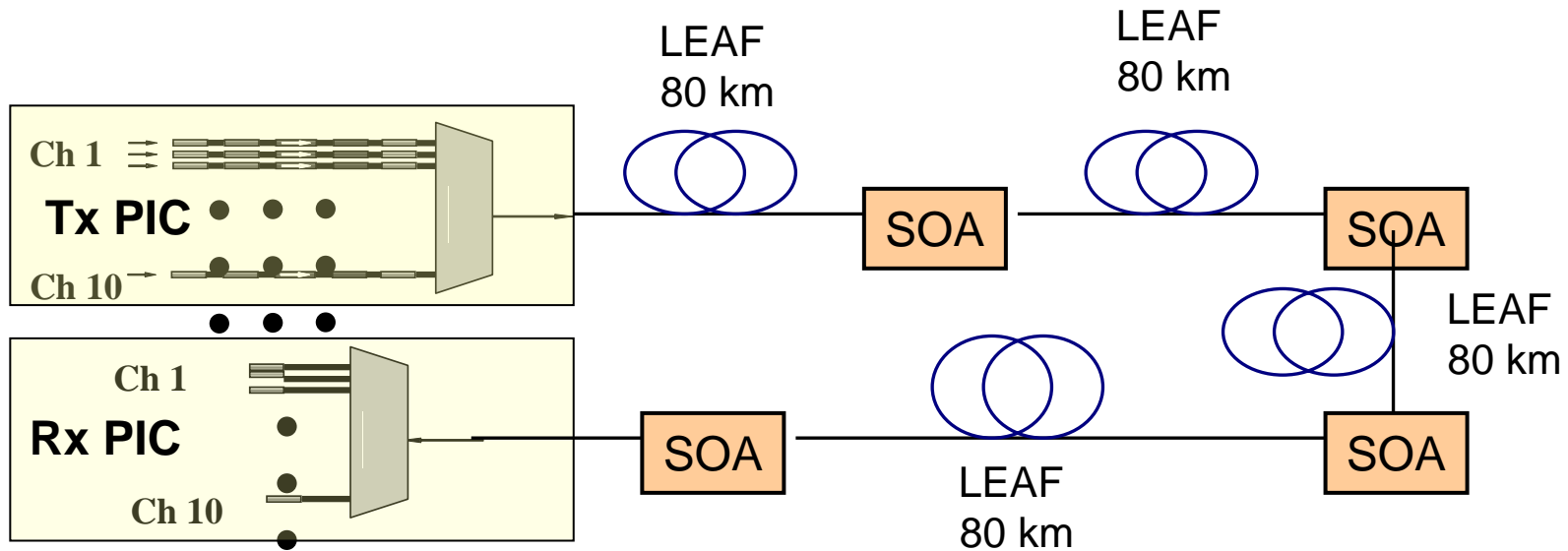

SOAs Can Allow Full Fiber Spectrum

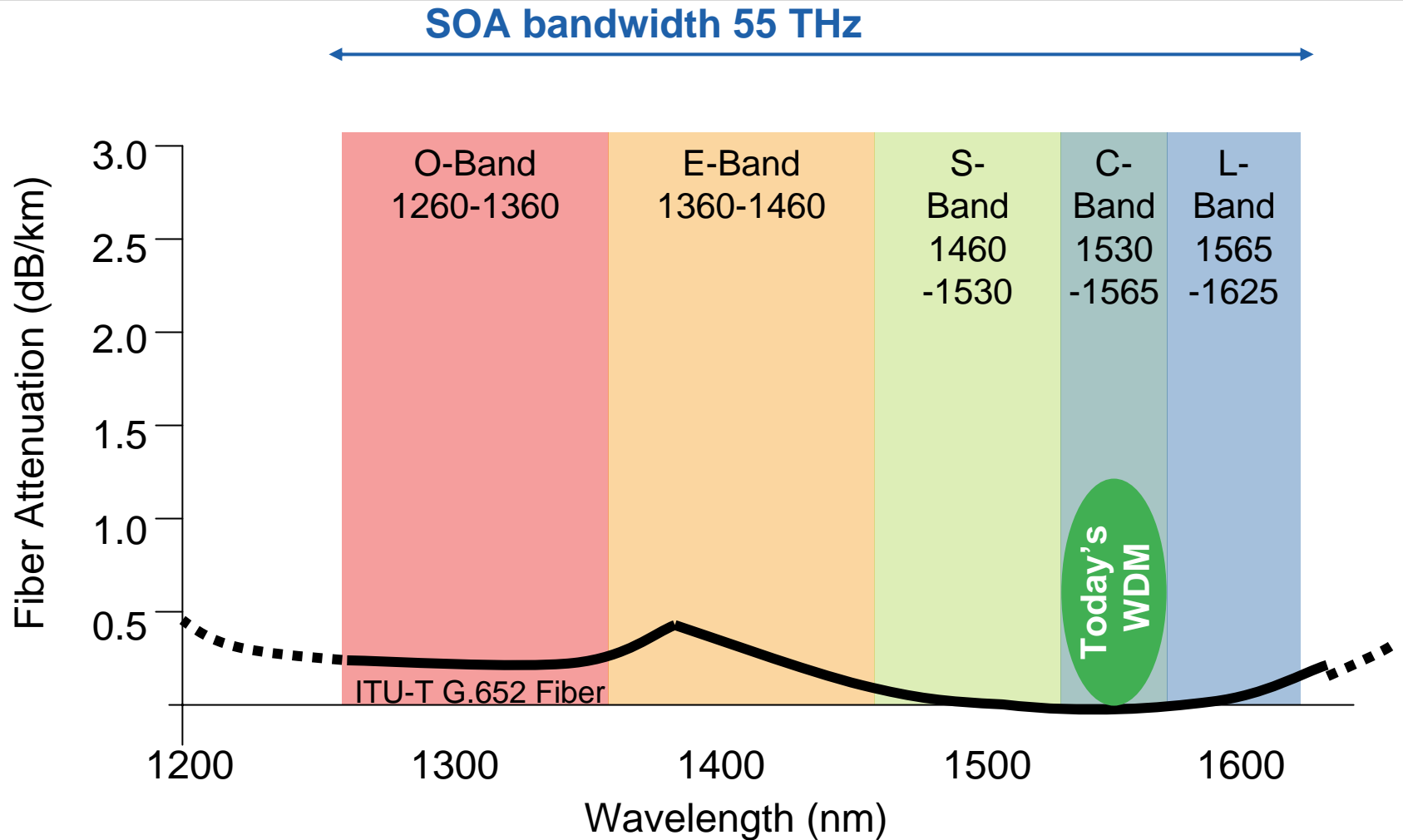

Around 100 Tb/s fiber capacity enabled by PIC based SOAs

Raman Demonstration over 1,650 km

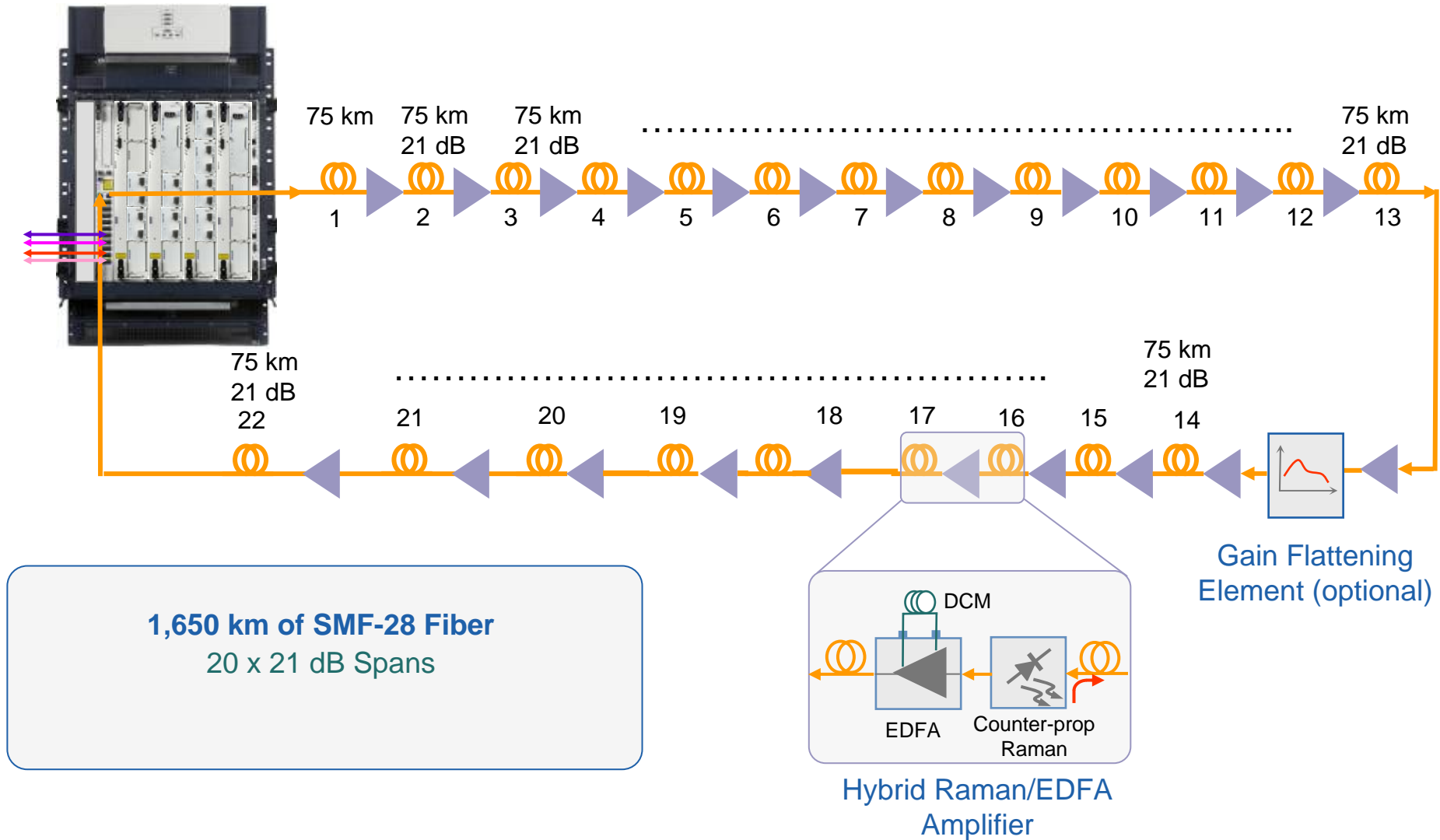

Summary

- “Bits per Chip” is the only metric that correlates to all the demands of network scaling
 - Capacity
 - Power
 - Cost
 - Size
 - Flexibility
 - Reliability
- 400 Gb/s going to 4 Tb/s

A photograph of a factory interior. In the foreground, a white machine with a yellow vertical beam is visible. The word "Infonera" is printed in blue on the white surface. In the background, two men in business attire are standing and talking. The factory has a complex structure with yellow and white elements.

Infonera

Thank You