

Linear Microwave-Domain Dispersion Compensation of 10-Gb/s Signals using Heterodyne Detection

A. H. Gnauck, J. Sinsky, P. J. Winzer, and S. Chandrasekhar

*Lucent Technologies, Bell Laboratories, Holmdel, NJ 07733
Tel: 732-888-7197, Fax: 732-888-7074, gnauck@lucent.com*

Abstract: We demonstrate heterodyne detection of 10-Gb/s signals, and subsequent linear compensation of fiber chromatic dispersion in the microwave domain. We achieve 375-km transmission (with 2-dB penalty) over standard single-mode fiber using duobinary modulation and a single passive microwave dispersion-compensating element.

©2005 Optical Society of America

OCIS codes: (060.2330) Fiber optics communications; (060.1660) Coherent communications

1. Introduction

Recently, there has been intense interest in extending the reach of 10-Gb/s transmission systems without the use of dispersion-compensating fiber (DCF) or other optical elements. One technique is the use of advanced dispersion-tolerant modulation formats such as duobinary [1,2]. Another technique is to apply maximum-likelihood sequence estimation (MLSE) and other digital electronic signal-processing techniques after square-law detection in the receiver [3,4]. Typically, at the forward-error-correction (FEC) rate of 10.7 Gb/s, 200 km of standard single-mode fiber (SSMF) can be bridged using a combination of these methods. More recently, pre-distortion of the transmitted waveform through signal processing techniques has been proposed to compensate the effects of fiber dispersion [5]. By adjusting the pre-distortion, it is possible to accommodate varying amounts of dispersion. However, if this process is to be automated, it has the disadvantage of requiring knowledge of the channel (dispersion in the fiber path) at the transmitter. This information may have to be fed back to the transmitter from the receiver. Moreover, finite laser linewidths may act unfavorably on this technique [5]. A receiver-only dispersion-compensation approach avoids these problems.

In this paper we report a simple linear dispersion-compensation strategy that is applied at the receiver, and can be combined with receive-side digital signal-processing techniques. We use heterodyne detection to translate the optical spectrum into the microwave regime. A passive, linear dispersive element is then used to compensate for fiber dispersion. Coherent detection was vigorously studied over a decade ago [6]. At that time, compensation in the microwave domain of a small chromatic dispersion penalty in a 4-Gb/s frequency-shift-keyed (FSK) transmission system was demonstrated [7]. However, with the arrival of optical amplifiers and DCF, work in this area was largely abandoned. Presently, advances in laser stability, electronic amplifiers, and microwave devices and materials make coherent detection of high-speed optical signals much more practical. Simultaneously, there has developed a desire to compensate chromatic dispersion without the cost and disruption of DCF installation, as well as a need to accommodate variations in chromatic dispersion of the disjoint paths within optical networks. The technique reported here is well suited to these tasks. Heterodyne detection can be applied to various modulation formats [6]. Here we demonstrate coherent detection and dispersion compensation of both non-return-to-zero (NRZ) and duobinary signals after transmission through SSMF. Using a fixed dispersive microstripline, the dispersion of 220 km of fiber (3750 ps/nm) is compensated. This allows 170- to 270-km NRZ transmission with ≤ 2 -dB penalty, while the duobinary format provides an impressive 100- to 375-km transmission range. By combining duobinary transmission and a coarse, stepwise compensation approach, it is possible to accommodate a wide range of dispersion values.

2. Transmission Experiment

In order to explore the performance of coherent detection, a 10.7-Gb/s (FEC rate) transmission system was assembled, as shown in Fig. 1. The transmitter employed an x-cut, nominally chirp-free LiNbO₃ Mach-Zehnder modulator, and was driven by a 10.7-Gb/s NRZ electrical pseudo-random bit stream (PRBS) of length $2^{23} - 1$. To obtain NRZ optical modulation, the modulator was biased at quadrature and the peak-to-peak electrical drive voltage was set to V_π . To obtain the duobinary format, the modulator was biased at a null, a 3.0-GHz electrical filter was added in the drive-signal path, and the peak-to-peak electrical drive voltage was increased to $2 V_\pi$. The optical signal source was a distributed-feedback (DFB) laser operating at a wavelength of 1551.72 nm (193.2 THz).

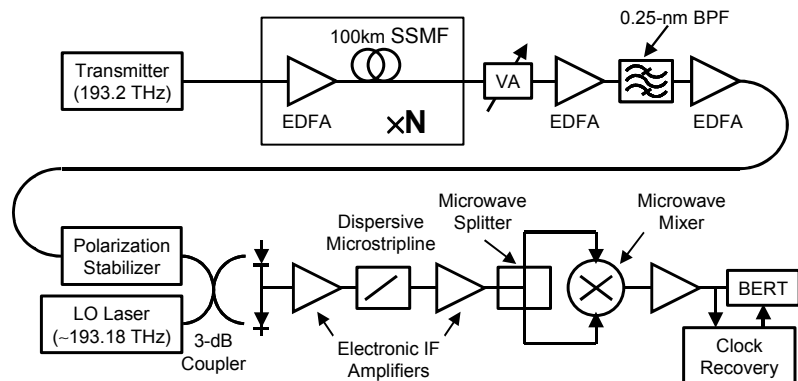

Fig. 1. Experimental layout.

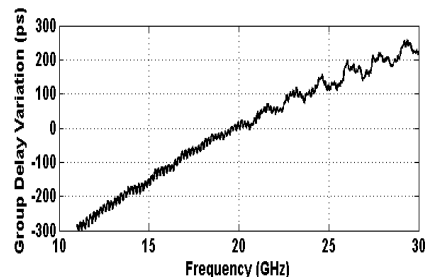

Figure 2. Dispersion of microstripline.

Each full transmission span consisted of approximately 100 km of SSMF. Shorter lengths were used to map out the dispersion tolerance below 100 km, or between integer numbers of spans. The average dispersion was 17.2 ps/nm/km at the signal wavelength. The average launched power into each span was +1 dBm, resulting in nearly linear transmission. The received signal was amplified and filtered through a 0.25-nm-bandwidth optical grating filter. A variable attenuator (VA) in front of the amplifier was used to adjust the received optical signal-to-noise ratio (OSNR).

Coherent detection requires either polarization tracking or polarization diversity. After amplifying, we passed the signal through a commercial automated polarization stabilizer and then combined it in a 3-dB coupler with the output of our local oscillator (LO) DFB laser. The LO laser power was +9 dBm. The wavelength was offset with respect to the signal laser to give a beat frequency (or intermediate frequency, IF) of nominally 20 GHz. The signals from the coupler outputs were detected on a balanced photodiode pair. The electrical IF signal was amplified and sent through a 52-cm-long microstripline that provided 30 ps/GHz (equivalent to 3750 ps/nm) of dispersion. The 50-Ω microstripline was fabricated on a 25-mil-thick substrate (dielectric constant = 10.2, loss tangent = 0.0035). The measured dispersion is shown in Fig. 2. The signal was demodulated by beating it against itself using a commercial microwave mixer. The resulting baseband signal was amplified for bit-error-rate (BER) testing.

The electrical IF signal from the balanced detector is shown in Fig. 3 for NRZ and duobinary modulation, with the center frequency set to 20 GHz. A heterodyne receiver is not very sensitive to the chosen IF. In practice, bandwidth limitations of elements such as the amplifiers, splitter, and mixer set a usable range. This range was investigated in back-to-back measurements of NRZ performance (without the dispersive microstripline). As shown in Fig. 4, the IF frequency could be varied from 19 GHz to 23 GHz with less than a 1-dB penalty in the OSNR (reported in a 0.1-nm noise bandwidth) required to reach a BER of 1×10^{-3} . Our DFB sources were stable to well below 1 GHz. Consequently, frequency locking of the LO to the signal was not required or implemented. In transmission experiments (using the microstripline), the optimum IF was found to be around 20.5 GHz, and this nominal IF was used in all the remaining measurements.

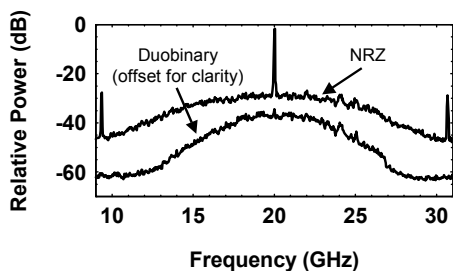

Figure 3. Electrical IF NRZ and duobinary spectra.

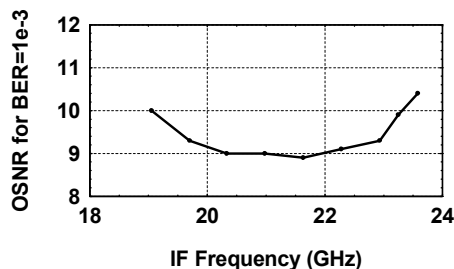

Figure 4. Back-to-back sensitivity as a function of IF.

We first compared direct and coherent detection of NRZ format in back-to-back measurements without the dispersive microstripline. The results are shown in Fig. 5. Both techniques give similar performance at high error rates, although coherent detection performs somewhat worse at low error rates. This may be due to intersymbol interference from non-ideal performance of the various microwave devices. The received eye patterns are shown in

the inset. Note that the coherently detected eye appears more low-pass filtered, due to the limited bandwidth (DC-8 GHz) at the output port of the microwave mixer.

We next conducted NRZ transmission experiments. Using direct detection, a 2-dB dispersion penalty was reached at less than 60 km, as shown in Fig. 6. Using coherent detection and electrical dispersion compensation, distances of approximately 170-270 km could be bridged with ≤ 2 -dB penalty relative to the performance at the optimum distance of 220 km. Also shown in Fig. 6 are results for direct detection and coherent detection of a duobinary signal. Direct detection demonstrates the well-known robustness against dispersion. Similarly, coherent detection and electrical dispersion compensation of the duobinary signal exhibits a wide tolerance to dispersion. Distances of 100-375 km (dispersion of 1720-6450 ps/nm) could be bridged with ≤ 2 -dB penalty. By using the duobinary format with coherent detection, it is possible to cover a large range of fiber dispersion values by choosing, or automatically switching, among a few passive microwave compensators.

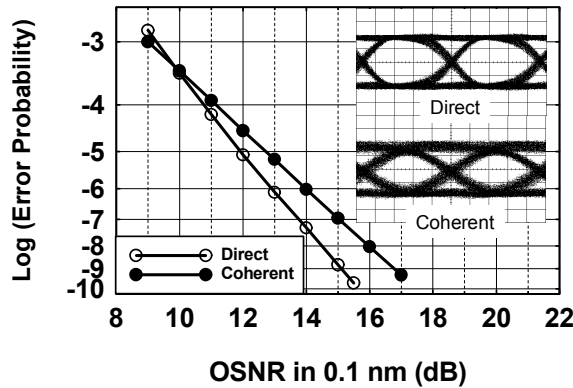

Figure 5. NRZ back-to-back performance. Insets: Eye diagrams.

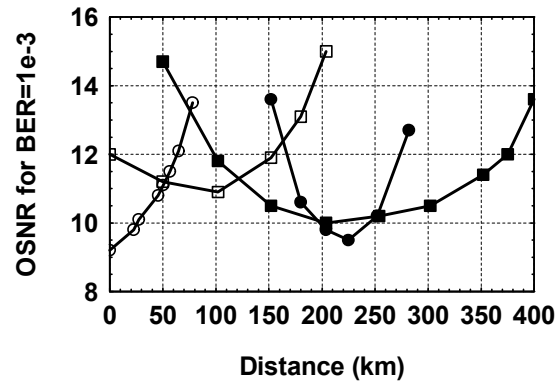

Figure 6. Transmission performance for NRZ (circles) and duobinary (squares). Open markers: direct detection. Solid markers: coherent detection with dispersion compensation.

3. Conclusion

We have demonstrated the use of coherent detection to allow linear compensation of fiber chromatic dispersion in the microwave regime. Using a single passive element, we compensated the dispersion of 220 km of standard single-mode fiber, allowing us to achieve 10.7-Gb/s, 170- to 270-km NRZ transmission, and 100- to 375-km duobinary transmission with ≤ 2 -dB penalty. This technique is applicable to other modulation formats, and can easily be extended to higher values of dispersion by shifting the dispersion-penalty curve to higher values, in complete analogy to transmit-side pre-distortion. Duobinary signaling combined with this electrical dispersion compensation is especially significant, as a small selection of simple, low-cost, and passive microwave compensators can cover a wide range of dispersion, without the need for high-speed digital signal processing.

4. References

1. D. Penninckx, M. Chbat, L. Pierre, and J.-P. Thiery, "The phase-shaped binary transmission (PSBT): a new technique to transmit far beyond the chromatic dispersion limit," *Photon. Technol. Lett.* Vol 9, No. 2, pp. 259-261 (1997).
2. W. Kaiser, T. Wuth, M. Wichers, and W. Rosenkranz, "Reduced complexity optical duobinary 10-Gb/s transmitter setup resulting in an increased transmission distance," *Photon. Technol. Lett.* Vol 13, No. 8, pp. 884-886 (2001).
3. P. J. Winzer, F. Fidler, M. J. Matthews, L. E. Nelson, S. Chandrasekhar, L. L. Buhl, M. Winter, and D. Castagnozzi, "Electronic equalization and FEC enable bidirectional CWDM capacities of 9.6 Tb/s-km," *OFC 2004*, postdeadline paper PDP7 (2004).
4. A. Farbert, S. Langenbach, N. Stojanovic, C. Dorschky, T. Kupfer, C. Schulien, J.-P. Elbers, H. Wernz, H. Griesser, and C. Glingener, "Performance of a 10.7 Gb/s receiver with digital equalizer using maximum likelihood sequence estimation," *ECOC 2004*, postdeadline paper PD Th4-1-5 (2004).
5. M. M. El Said, J. Sitch, and M. I. Elmasry, "An electrically pre-equalized 10-Gb/s duobinary transmission system," *J. of Lightwave Technol.* Vol. 23, No. 1, pp. 388-400 (2005).
6. R. A. Linke and A. H. Gnauck, "High-capacity coherent lightwave systems," *J. of Lightwave Technol.* Vol. 6, No. 11, pp. 1750-1769 (1988).
7. K. Iwashita and N. Takachio, "Compensation of 202 km single-mode fibre chromatic dispersion in 4 Gbit/s optical CPFSK transmission experiment," *Electronics Letters* Vol. 24, No. 12, pp. 759-760 (1988).